

Qty. Description

1 **MAGNA1 25-100**



Note! Product picture may differ from actual product

Product No.: [97924145](#)

The Grundfos MAGNA1 is a circulator pump with permanent magnet motor and easy selection of pump setting. The MAGNA1 will fit both heating, cooling and domestic hot water circulation applications perfectly, making it the obvious choice for almost any building project – old or new.

The pump is a canned-rotor type, i.e. pump and motor form an integral unit without shaft seal and with only two gaskets for sealing.

The bearings are lubricated by the pumped liquid. A pump with no maintenance requirements and extremely low life cycle cost.

The pump has an intuitive user interface, which is especially fit for replacement of older circulators. The ideal choice for basic performance needs in applications where system communication is not required.

97924145 MAGNA1 25-100

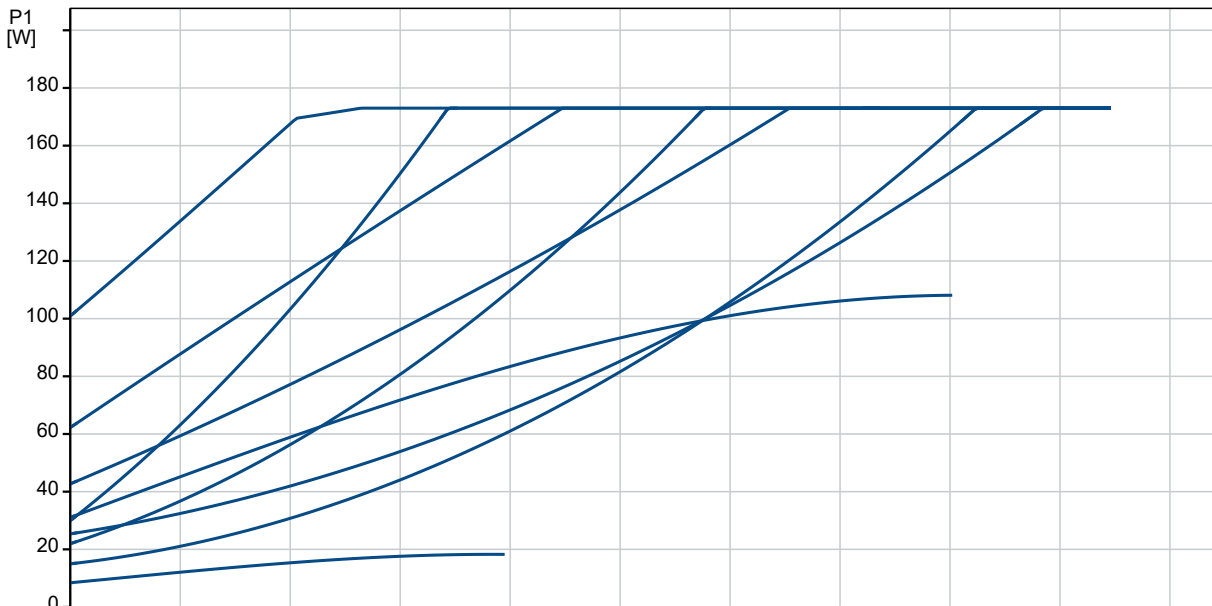
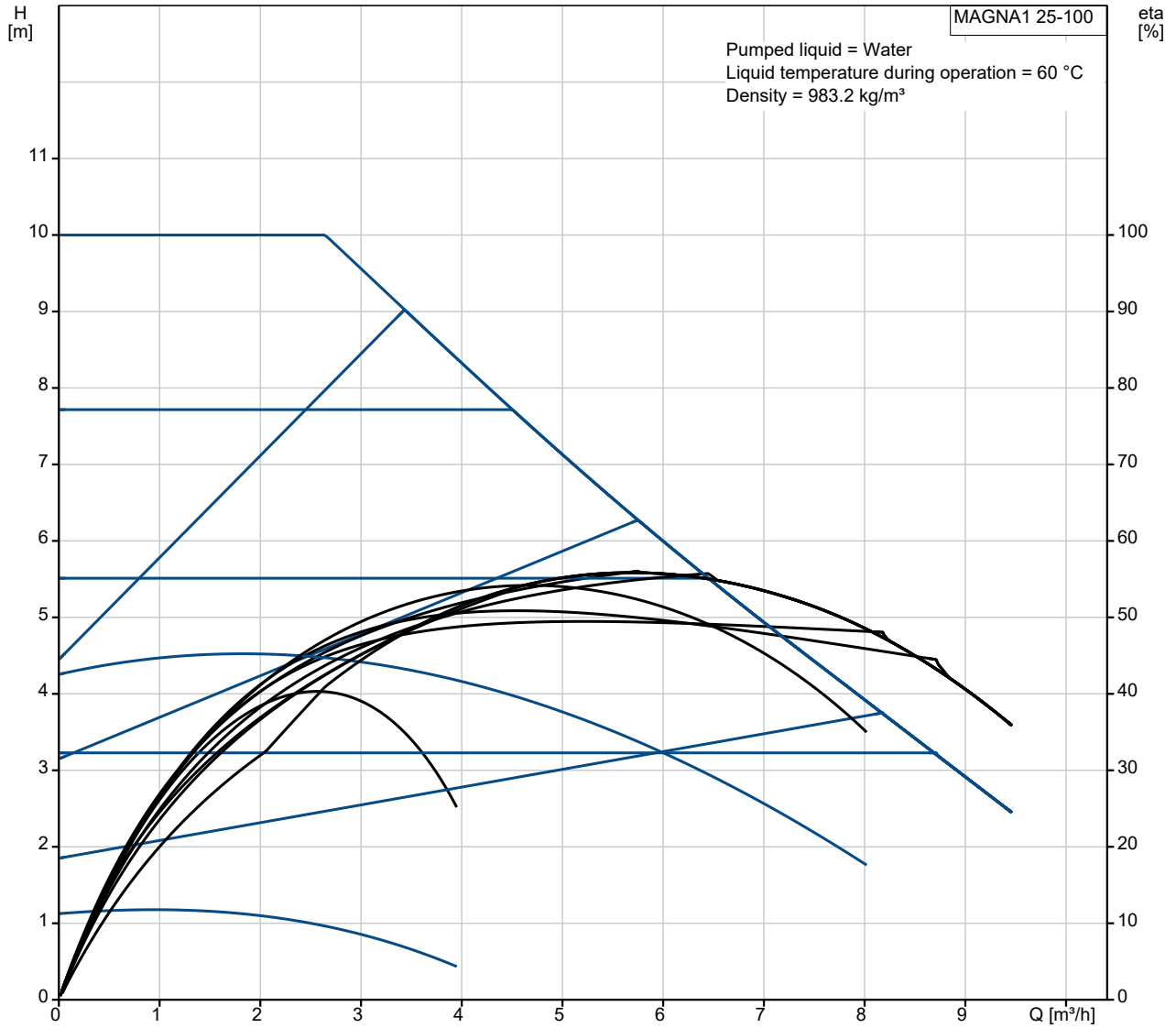

Description	Value
General information:	
Product name:	MAGNA1 25-100
Product No:	97924145
EAN number:	5710626492190
Price:	
Technical:	
Head max:	100 dm
TF class:	110
Approvals on nameplate:	CE, VDE, EAC, CN ROHS
Model:	A
Materials:	
Pump housing:	Cast iron
Pump housing:	EN-GJL-200
Pump housing:	ASTM A48-200B
Impeller:	PES 30%GF
Installation:	
Range of ambient temperature:	0 .. 40 °C
Maximum operating pressure:	10 bar
Pipe connection:	G 1 1/2"
Pressure rating:	PN10
Port-to-port length:	180 mm
Liquid:	
Pumped liquid:	Water
Liquid temperature range:	-10 .. 110 °C
Selected liquid temperature:	60 °C
Density:	983.2 kg/m ³
Electrical data:	
Power input - P1:	9 .. 176 W
Mains frequency:	50 / 60 Hz
Rated voltage:	1 x 230 V
Maximum current consumption:	0.09 .. 1.42 A
Enclosure class (IEC 34-5):	X4D
Insulation class (IEC 85):	F
Others:	
Energy (EEI):	0.22
Net weight:	4.38 kg
Gross weight:	4.78 kg
Shipping volume:	0.012 m ³
Norwegian NRF no.:	9042064

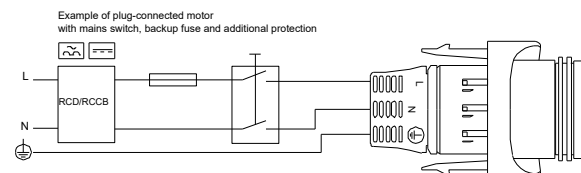
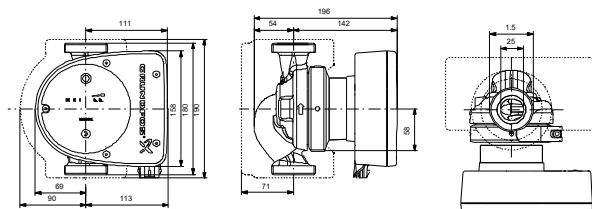
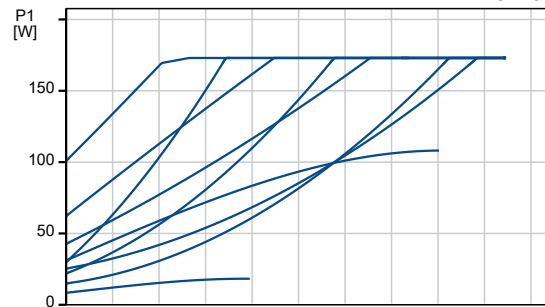
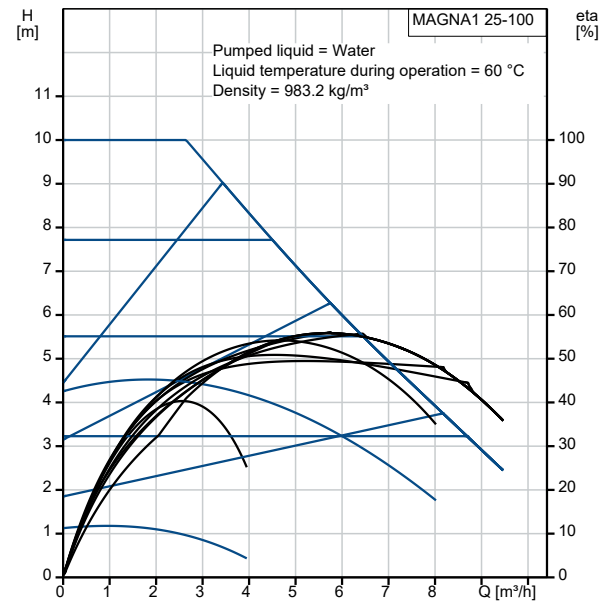

97924145 MAGNA1 25-100

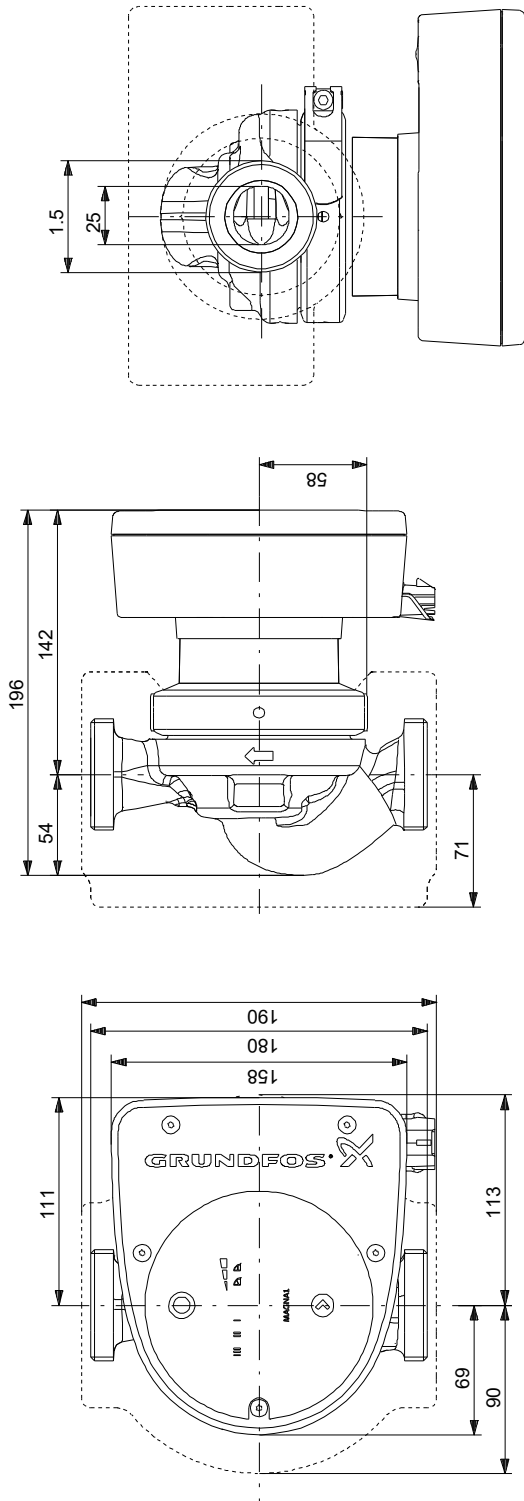

Note! All units are in [mm] unless others are stated.
Disclaimer: This simplified dimensional drawing does not show all details.

97924145 MAGNA1 25-100

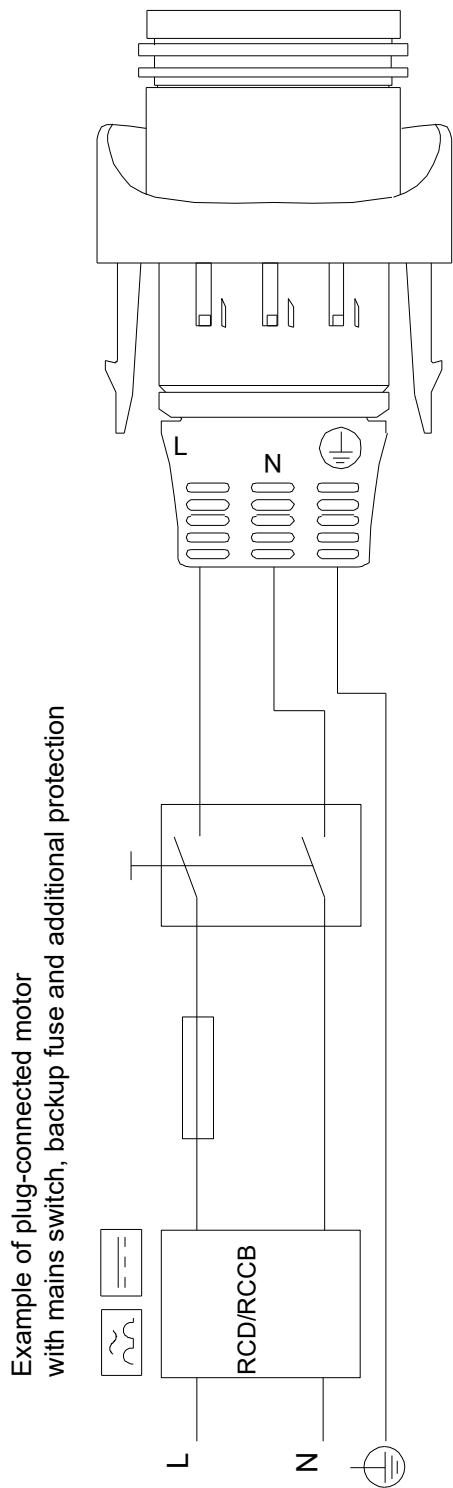

Note! All units are in [mm] unless others are stated.